

Uniclass		
L217241		
CI/SfB		
(99.64)	Xh	

February 2013

# **GATIC** Access Covers

Specialised Engineering. Special Advice.  
Installation Guide

# GATIC

## Installation

### Single cover and frames

- 1 Prepare the rebate in accordance with dimensions given in the relevant tables within this publication and/or accompanying drawings.
- 2 Remove cover from frame and place frame squarely over pit ensuring it does not overhang any edges.
- 3 Screw down on the frame leveling bolts until the desired height is achieved.
- 4 Place formwork around inside of pit so that the timber is approximately 10mm above the bottom of the frame. This will prevent spalling of the frame.

Do not pour concrete at this stage.

- 5 Clean off cover and frame sealing faces and replace cover into frame.
- 6 Adjust the frame level so that the cover is not rocking. Tap down the corners of the covers with a balk of timber to make sure it is seated fully.
- 7 If covers are of the recessed design you will need to cover the 4 holes in the cover base with a small metal or slate plate.
- 8 Insert the plastic keyhole plugs and mask off with tape.
- 9 Pour concrete in the covers, if of the recessed type, and around the frames making sure that you thoroughly tamp and vibrate as you go.
- 10 Allow concrete to cure overnight.
- 11 Remove cover and strike shuttering.
- 12 Clean faces of covers and frame and apply a thin film of graphite grease to the seating faces.
- 13 Replace cover into the frame and tap down with a balk of timber.
- 14 Allow the concrete to fully mature before any load is applied.

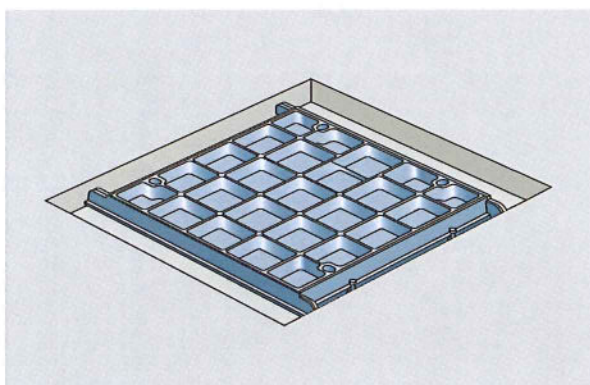
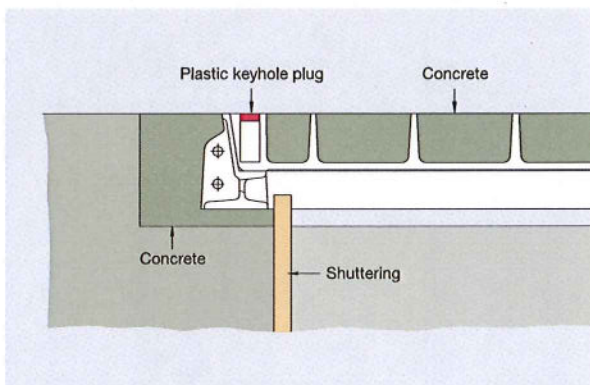
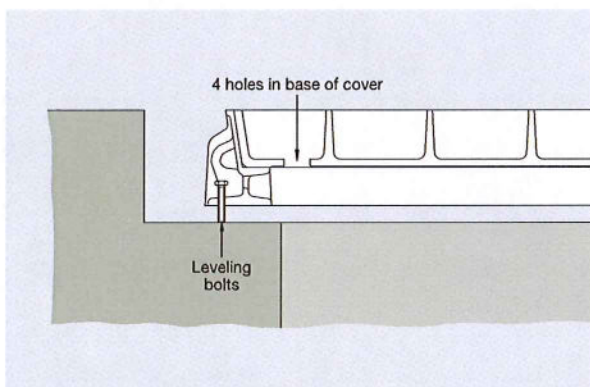
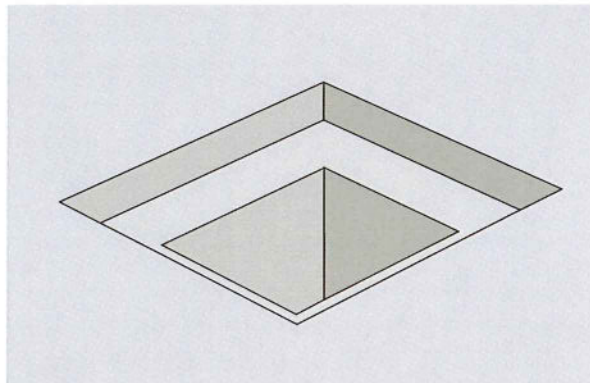

# Installation

## Ducts and trenches

- 1 Prepare the rebate in accordance with dimensions given in the relevant tables within this publication and/or accompanying drawings. They are also numbered in sequence.
- 2 Covers and frames are supplied pre-matched and banded together.

Do not remove banding at this stage.

- 3 Commence at one end of the pit, or if there is a junction then commence at this point. Identify the relevant covers and frames at this location.
- 4 Place first assembled section squarely over the pit ensuring it is in alignment with the centre of the pit.
- 5 Identify the next assembly. This is done by locating the next number in the sequence, offering up to the first portion and loosely bolting the frame together. Numbers are painted on the ends of the covers to correspond with the drawings supplied.
- 6 Adjust the height of the frames to the required level by using the leveling bolts in the frame.
- 7 Repeat along the length of the trench making sure the covers are following a straight line.
- 8 Visually check that your covers are in the correct frames and order by looking for the random grinding nicks around each cover perimeter on the top surface.
- 9 In sections, remove covers from frames and place formwork around inside of pit so that the timber is approximately 10mm above the bottom of the frame. This will prevent spalling of the frame.

Do not pour concrete at this stage.

- 10 Clean off covers and frame seating faces and replace cover into the frame.
- 11 Check that the grinding nicks still correspond.
- 12 Adjust the frame level so that the cover is not rocking. Tap down the corners of the covers with a balk of timber to make sure it is seated fully.
- 13 Using the assembly clamps provided, clamp the covers to the frames and across cover to cover joints. This will ensure that the covers are seated properly.
- 14 Moving round the frame, with the covers in place, tighten the frame bolts making sure you do not damage the lead packers or over-tighten the bolt.
- 15 If covers are of the recessed design, you will need to cover the small holes in the cover base with a small metal or slate plate.

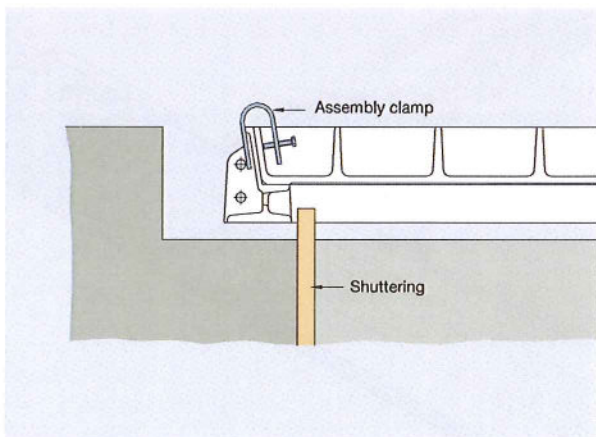
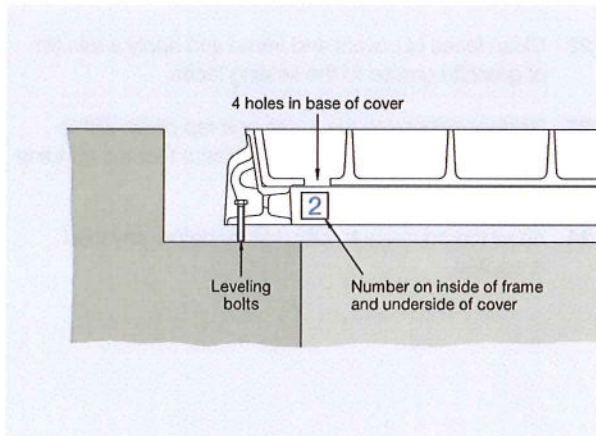
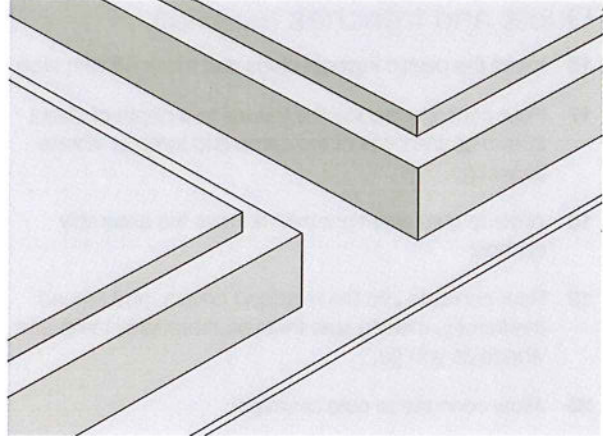

# GATIC

## Installation

### Ducts and trenches (continued)

- 16 Insert the plastic keyhole plugs and mask off with tape.
- 17 Pour concrete around the frames to a depth of about 25mm up the back of the frame and tamp or vibrate as you go.
- 18 Allow to cure overnight then remove the assembly clamps.
- 19 Pour concrete into the recessed covers, and around the frames, making sure that you thoroughly tamp and vibrate as you go.
- 20 Allow concrete to cure overnight.
- 21 Remove cover and strike shuttering.
- 22 Clean faces of covers and frame and apply a thin film of graphite grease to the seating faces.
- 23 Replace cover into the frame and tap down with a balk of timber. Once again make sure that the grinding nicks match up.
- 24 Allow the concrete to fully mature before any load is applied.

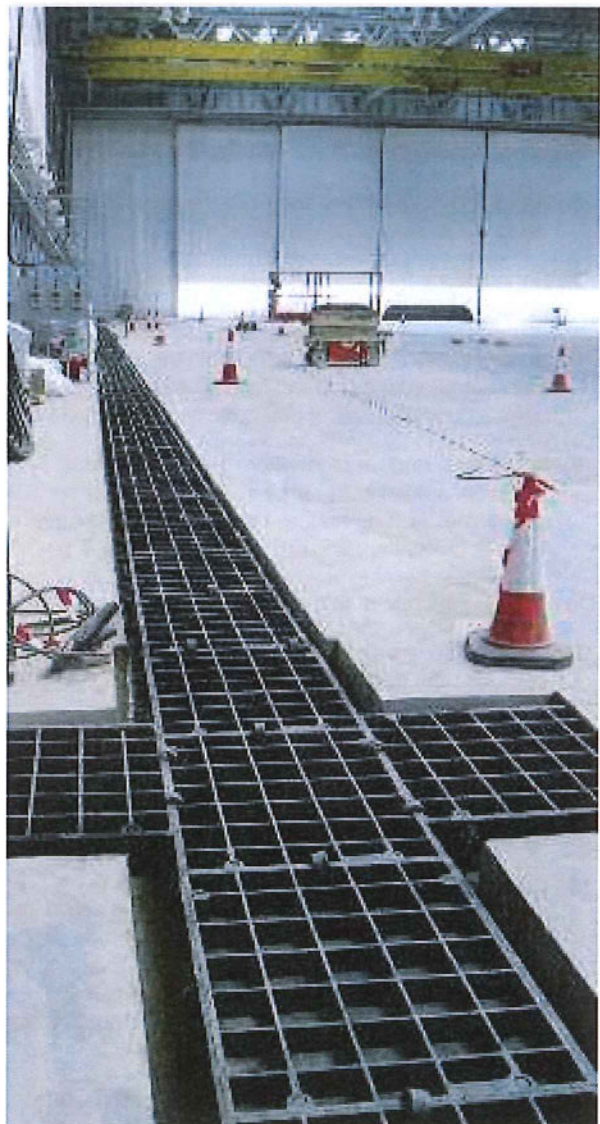
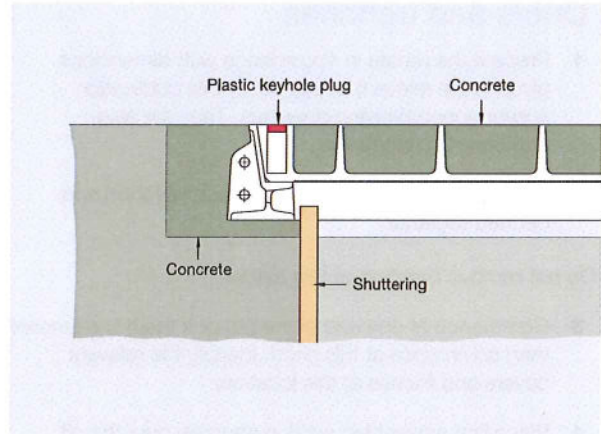
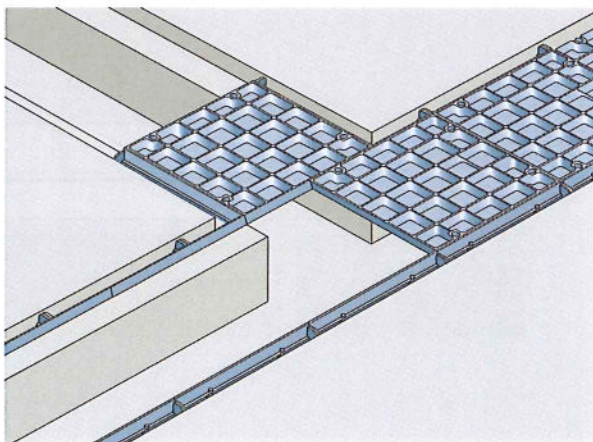

# Installation

## Multispan covers and frames

Form the frame and wallbox rebates around the pit strictly in accordance with Gatic's drawing. It is important to follow the stated dimensions otherwise the multispan cover will not fit.

The frame is delivered in sections together with beam assemblies and covers. Ensure that the end frames match with the side frame components.

The end frames can be identified as those sections with the beam end wallbox forming part of their construction. Frame sections and beam assemblies are numbered to help locate the cover positions.

Identification numbers are shown on the cover layout drawing supplied. Numbers can be found painted on the ends of covers, beams and outside faces of frames. Number tags are also fixed to the underside of the cover and also to the frame and beams.

The lowest numbers in each row of covers indicate that this is the front end of the unit.

- 1 Position the front end frames in the wallbox pockets and loosely join the sections together in the middle and at the corners.
- 2 Locate the side frame assemblies. These are handed so that they only fit on the correct side of the cover, and offer up to the back end frames.

Remember that there are a number of small frame pieces that make up a straight frame.

- 3 Check that lead spacers at the frame joints have not been damaged otherwise the frame will no longer mate with the cover. Again loosely bolt the frames together.
- 4 Using the large 'Tommy Bar' gradually screw down on the levelling bolts on the bottom of the wallboxes until the top of the frame is approximately level with the finished floor level.
- 5 Now using the small 'Tommy Bar' adjust the side frames up to approximate finished level.
- 6 Locate the correct beam assembly, look for the numbers painted on the beam and corresponding tags on the frame, and lower into the wallboxes.
- 7 Tap down on the filler block, using a rubber mallet, and then, using the small assembly clamp, clip the end of the beam into the wallbox. (If the filler block is not flush then the beam is not seated correctly in the wallbox and you will need to adjust it accordingly).
- 8 Dimensionally check the frame is roughly square and not overhanging the edge of the pit.

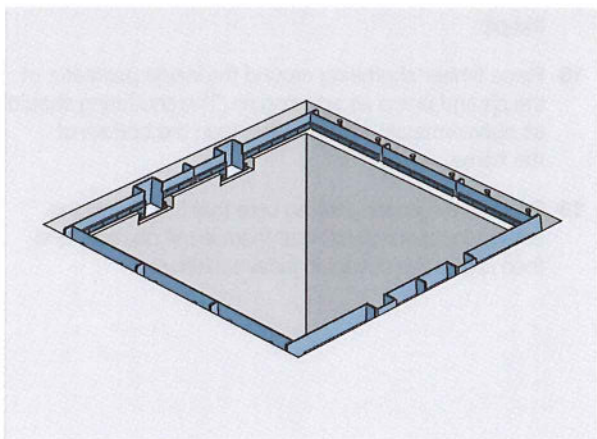
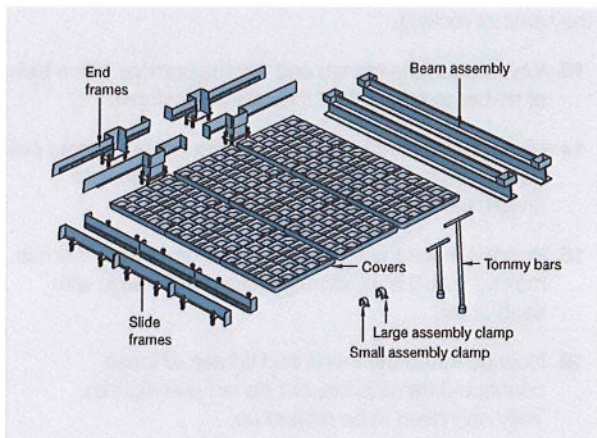
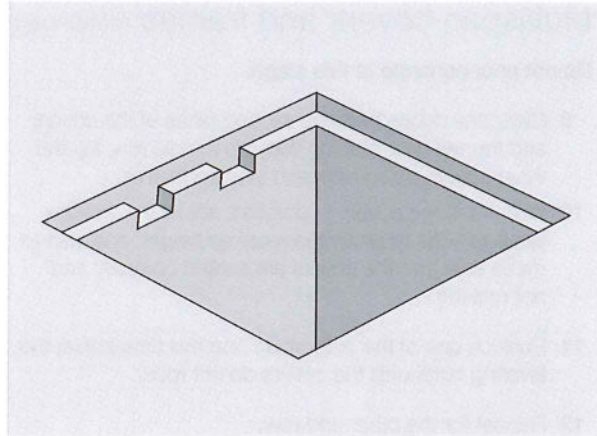

### Multispan covers and frames (continued)

Do not pour concrete at this stage.

- 9** Clear any debris from the seating faces of the covers and frames and, starting with the middle row, lay the three covers down between the two beams.
  - 10** With the three covers in position, adjust the wallbox levelling bolts to attain the required height, and also to make sure that the covers are seated correctly and not rocking.
  - 11** Position one of the outer rows and this time adjust the levelling bolts until the covers do not rock.
  - 12** Repeat for the other end row.
- The covers are now sound enough to walk on to check that they are not rocking.
- 13** Walk across the covers and tap the corners with a balk of timber to ensure that they are firmly down.
  - 14** Using the assembly clamps provided, you can now pull the covers tightly together and into the frames to ensure the unit is correctly seated.
  - 15** Visually check the top edges of the covers and frames making sure that random grinding marks align with each other.
  - 16** Now go round the frame and tighten all loose connected frame joints, but do not over-tighten. They only need to be nipped up.
  - 17** Remove the covers and carefully stack at the side of the pit.
  - 18** Place timber shuttering around the inside perimeter of the pit and brace as appropriate. The shuttering should sit approximately 10mm higher than the bottom of the frame.
  - 19** Replace the covers, taking care that they are in the correct location, check that there is still no rock, and then clamp the covers in place as before.

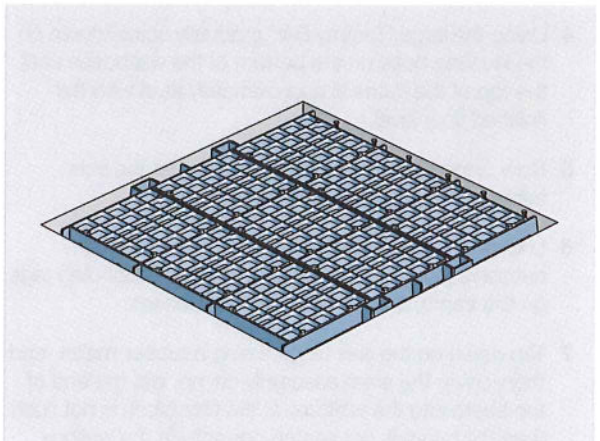
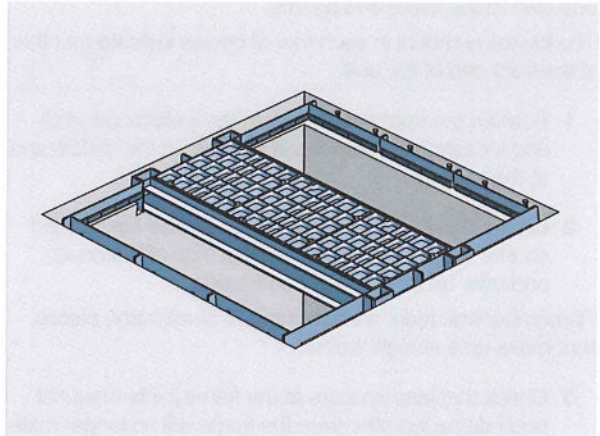
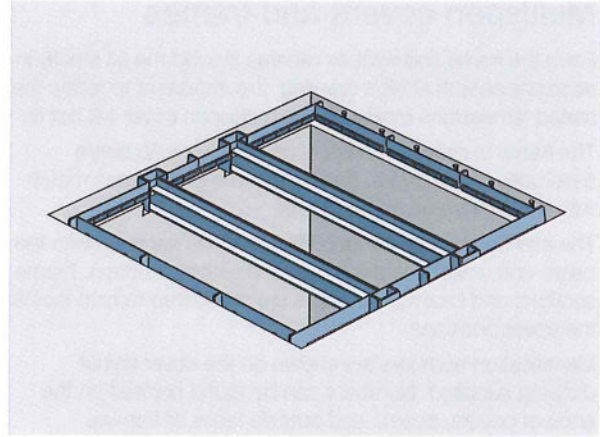



## Installation

### Multispan covers and frames

(continued)

- 20 Place small thin pieces of cut steel over the holes in the cover base plates, insert keyhole plugs and place masking tape over them.

The cover is now ready to receive concrete.

- 21 Leave the assembly clamps in place and part fill the rebate around the frame, going approximately 25mm up the back of the frame and thoroughly tamping or vibrating to ensure that it flows under the frame. Leave for 24 hours to set.
- 22 Remove clamps and proceed to infill around the rest of the frame and inside the covers, thoroughly tamping as you go.
- 23 Float off the surface to the desired texture.
- 24 Remove covers from the frames and strike the shuttering, checking that the concrete has fully flowed under the frame.
- 25 Clean off covers and beams.
- 26 Lightly grease the blocks on the end of the beams and place in position.
- 27 Lightly grease faces and covers and replace in frames, checking that the grinding marks align.
- 28 Allow the concrete to fully mature before any load is applied.

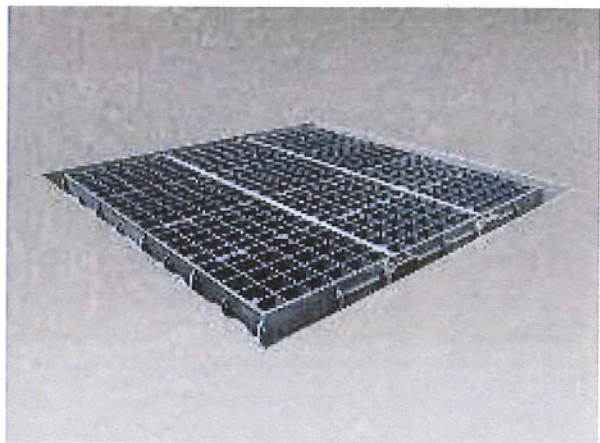
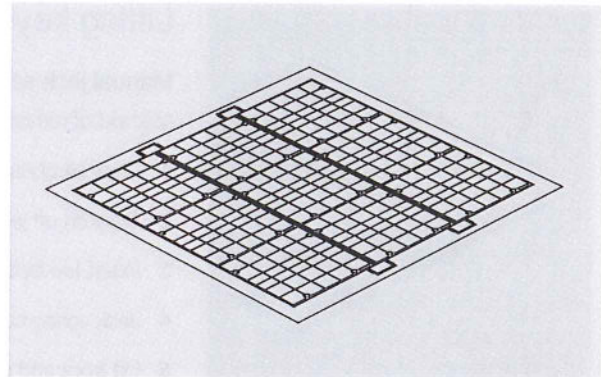

### Gatic tutorial

A Full tutorial on how to install Gatic Covers is shown on our website [www.gatic.com](http://www.gatic.com) or available on a CD upon request.



# GATIC

## Lifting keys



### Lifting keys

#### Manual jack screw key operation.

Method of removing Gatic covers using manual lifting keys.

- 1 Clear all obstructions from key holes.
- 2 Slacken off jack screw before placing key in position.
- 3 Insert tee bolt in the key hole, turn clockwise through 90° and tighten lock nut.
- 4 Jack screw can now be tightened to act on the frame and break seal.
- 5 Lift front and slide out cover.
- 6 Slacken off jack screw before replacing cover.

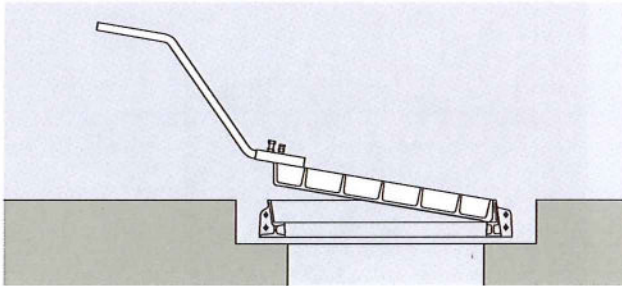

#### Long handled lifting keys (pair)

Not for use with mechanical or crane lifting.

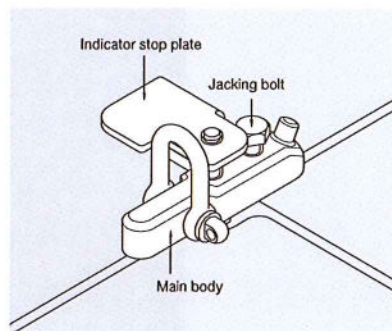
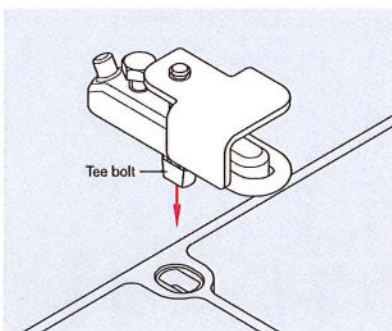
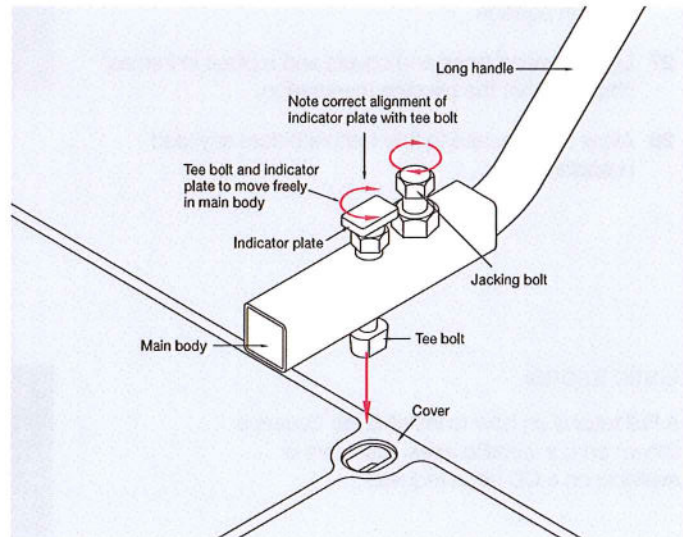
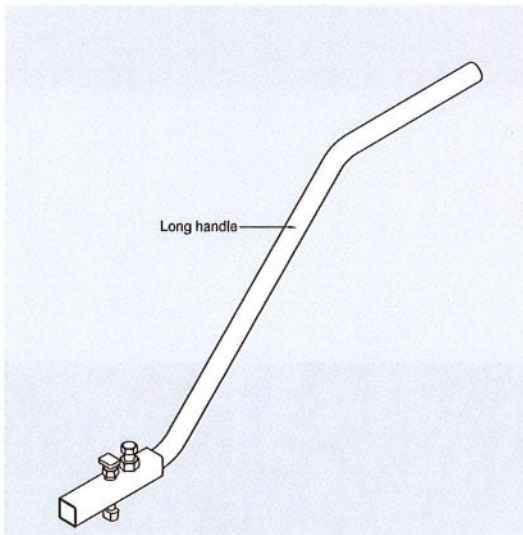

#### Mechanical lifting keys

Mechanical lifting keys are designed and tested for use with crane and other mechanical devices.